



GOING PLACES



Columbus MARC Region Since 1964, MAFCA Chapter since 2009

www.modelacolumbus.com

Upcoming Events

Nov 14—Membership Meet and Election of Officers

Dec 8—Christmas Party at The Pines



November 2019 Edition

"Money is like an arm or leg - use it or lose it."

- Henry Ford

President's Report

By Ron Lawson



Hello Membership!

We are coming to a close for our touring season by the end of October. If someone wants to have a tour for November or December please let us know.

As we end the year, I think about the old the Indianapolis Air Pump Company. It would have been 100 years old this year. Over the years the name changed as:

- 1919 Indianapolis Air Pump Company
- 1921 Indianapolis Pump and Tube Company, Inc.
- 1927 Noblitt-Sparks Industries, Inc.
- 1950 Arvin Industries, Inc.

The tire pump was a major product that they built and sold to Ford Motor Company for the Model T and Model A Fords.

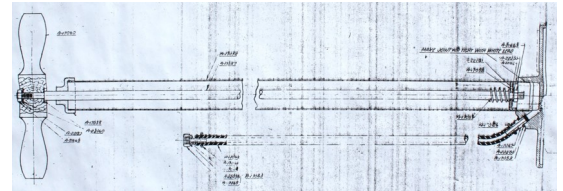

Our Christmas party is coming up on December 8 at 4:00 PM. MARC your calendars as this is going to be fun, fun, fun with great entertainment. It will be at the same place as last year; The Pines in Seymour.

September 19-23 we had the Gilmore Tour by way of Auburn, IN. Thirteen Model A's were on the tour with stops along the way. We visited two museums in Auburn (Auburn Cord Duesenberg Automobile Museum and Early Ford V-8 Foundation Museum), then traveled to the Gilmore in Michigan for the Model A days. Working our way home we stopped at Michigan City and the Indiana Dunes National Park and Indiana State Park. Thanks to Phil Sutton for a great tour that was enjoyed by all!



Shell Station at the Gilmore

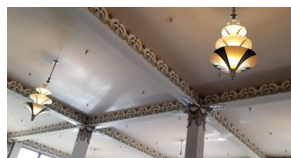

Ceiling at the ACD Museum



1936 Stainless Steel Ford at The Ford V-8 Museum

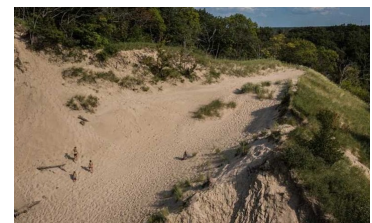

Dunes at State Park. Don't ask me how I took it!

See ya on the Road — **Ron**

FROM THE EDITOR

I made my annual pilgrimage to Hershey, PA to attend the 65th annual Eastern Division AACA National Fall Meet, October 9-12. Several others from the club were in attendance as well. As many of you know, this is the largest such antique car meet east of the Mississippi, if not the entire country. Lots of brass, nickel and chrome as well as plenty of 'patina'! About 3000 vendors and 1000 cars for sale on 140 acres and 1200 cars to be judged on 25 acres. It's big!

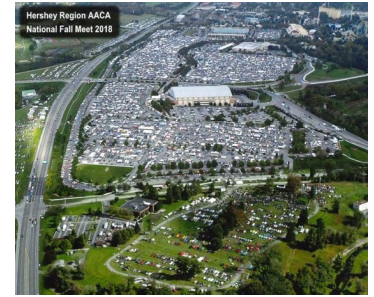

My family has a small stand along with some friends where we hawk parts from cars long sold or wrong parts bought. But I had a 'to-buy' list as well; hardtops for a Triumph Spitfire and TR3A as well as a brake shoe grinder. While I came up empty handed on the first two, I was successful on the latter. Fifteen minutes into my search on the first day and a few rows over from our stand, there it sat; a vintage Kwik-Way Model BA grinder still fresh with asbestos dust! After some negotiating and a \$20 deposit for the hand truck (boy that thing is heavy), I was its new proud owner. Why buy this? My trip to the MARC meet in Dearborn reminded me that my A brakes need attention. The Detroit stop-n-go traffic makes thin steel brake drums fade fast. Time for cast iron drums and a proper rebuild. Which must include proper shoe arching for a perfect match, right? A good winter project!

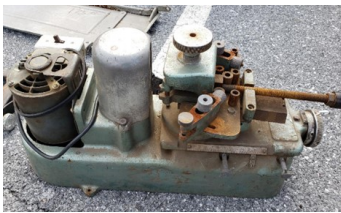

Tim Diehn, Newsletter Editor

Get Ready to Vote!

**Membership Meeting
November 14, 2019**

Voting for 2020 Club Officers

Do you want to be part of the leadership team of our club? Well now is your chance! If you are interested in a position, please contact one of the current officers listed on the back page of this newsletter. At the November Membership Meeting, we will be nominating and voting for the 2020 club officers.

Please make every effort to attend the next meeting for this important vote!!

Next Board Meeting

November 19th at 4pm, Jack and Linda
Sullivan's house, 613 N. Walnut, Seymour,
IN 47274

October 10 Membership Meeting Minutes

Ron Lawson called the meeting to order at 6:30 pm. Twelve members present.

Welcome:

Sickness: Gerald Alexander passed away In September.

Secretary report: In newsletter. Was approved.

Treasurer report: Beginning Balance: \$3,700.76. Income \$38 (50/50 \$18, Dues \$20). Expenses \$455.54 (Model A Youth \$100, MAFFI bus project \$100, 1/3 Tri Club Picnic \$120.42, Secretary of State Corporation Fee for 2 years \$22, MAFFI in memory of Gerald Alexander \$50 and web page and newsletter \$63.12). Ending Balance \$3283.22.

Old Business:

-Librarian, Wayne Arnholt has videos if interested. 812-522-1007

New Business:

-Tour report. September 19-23 Gilmore Tour by way of Auburn. Thursday – 13 Model A’s traveled to Auburn with stops along the way. Friday we visited the Auburn Cord Duesenberg Automobile Museum and the Early Ford V-8 Foundation Museum. We saw Joe Floyd’s 1936 Ford Collection to the V-8 Museum. He then built a 10,000 sq. ft. addition to house the collection. He then hired Group Delphi to create “Floyd Motors” an authentic Ford Dealership. After visiting the museums we traveled to Kalamazoo. On Saturday we traveled to Gilmore for Model A Days. Sunday we traveled to Michigan City and the Indiana Dunes National Park and the Indiana State Park. On Monday we headed home.

-Board of Directors Meeting October 15 at Ron Lawson’s home at 4:00 pm.

-Patches commemorating Drive Your Model A Day were passed out.

-Election of Club Officers will be in November.

-October 19 Fall Foliage Tour will be led by Jack and Linda Sullivan. We will meet at the Westhill Shopping Center at 10:30 am. We will be taking the back roads to the Story Inn for lunch. Following lunch we will stop at the Salt Creek Winery near Houston. After wine tasting we will return via the back roads to Columbus. Call Linda at 812-523-3674 if you have questions.

Submitted by Nora Dean.



CONDOLENCES

Gerald Alexander has gone to be with the Lord. Gerald passed away peacefully Friday, September 20, 2019. He and his late wife Lyn were active members of the Columbus Model A club for several years. Gerald most recently was a board member as well as a past president.

Visitation and funeral services were Tuesday September 24, at the Nineveh Christian Church, with burial at the church cemetery.



Tour Update:

Oct 19 Fall Foliage Tour (Sullivan)

Meet at the Westhill Shopping Center (west side of Columbus) at 10:30am. We will be taking the back roads to our lunch destination at Story Inn. Following lunch, we will stop at the Salt Creek Winery near Houston. After wine tasting, we will hit the back roads again for a leisurely drive back to Columbus. An questions, call Jack and Linda at 812-523-3674.



Christmas
PARTY

at

The Pines

December 8, 4:00pm

Please come join us for the annual Christmas Party at The Pines at 4171 N. US Highway 31, Seymour, IN 47274, Phone: (812) 522-4955.

In addition to a festive meal, we will have entertainment from The Lick Creek Band.

Cost to you is \$10 per person with the club picking up the remainder. **Please RSVP (and pay) Phil Sutton** (936 S, Hawthorne, Boomington, IN 47401, (812) 336-8672) **at the November 14 membership meeting.**



December 1 is the final RSVP date so we can get an accurate count for the restaurant.

Hope to see everyone there!



What Is It??



We continue to explore the Ford Patent Data Plate. This month we look at patent number 1,467,478 dated September 11, 1923 Metallic Vehicle Wheel.

Thanks to the **United States Patent and Trademark Office** for the information. —Ronnie Lawson

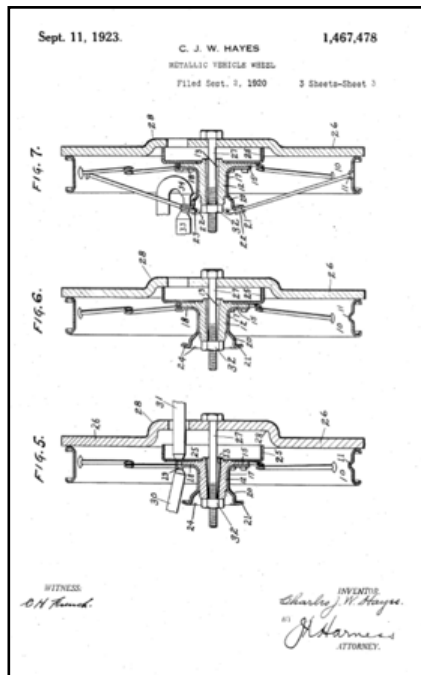
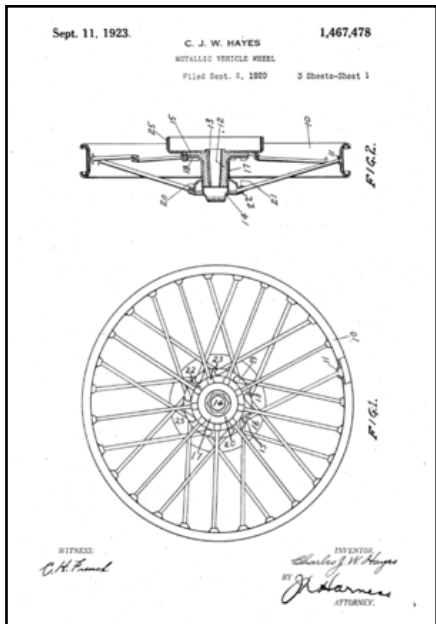

Patented Sept. 11, 1923.

1,467,478

UNITED STATES PATENT OFFICE.

CHARLES J. W. HAYES, OF ROCHESTER, MICHIGAN, ASSIGNOR TO FORD MOTOR COMPANY, OF DETROIT, MICHIGAN, A CORPORATION OF DELAWARE.

METALLIC VEHICLE WHEEL.

Application filed September 2, 1920. Serial No. 407,647.

To all whom it may concern:

Be it known that I, CHARLES J. W. HAYES, a citizen of the United States of America, residing at Rochester, county of Oakland, State of Michigan, have invented new and useful Improvements in a Metallic Vehicle Wheel, of which the following is a specification.

The object of my invention is to provide an improved metallic vehicle wheel of simple, durable, and inexpensive construction.

A further object of my invention is to provide a metallic vehicle wheel of the type which carries the load by the tension on the spokes as distinguished from those which carry the load largely by the compression on the spokes.

A further object of my invention is to provide such a wheel having tension spokes and means for welding the spokes in place in the wheel which will permit the spokes to be placed under tension.

A further object of my invention is to provide an improved hub construction especially adapted for a welded type of metallic wheel and, in combination with this structure, means for securing the brake housing through the wheel.

A further object of my invention is to provide improved means for centering the hub within the rim and to provide a method of welding spokes to the rim.

With these and other objects in view, my invention consists in the arrangement, combination and construction of the various parts of my improved device, as described in the specification, claimed in my claims, and shown in the accompanying drawings in which—

Figure 1 shows a side elevation of a wheel embodying my invention,

Figure 2 is a vertical central sectional view through the wheel shown in Figure 1.

Figure 3 shows an elevation of the hub members detached from the wheel and in position for assembly.

Figure 4 shows a top or plan view of one of the hub members, and

Figures 5, 6, and 7 show sectional views through the wheel and assembly jig and illustrate the manner of assembly.

Referring to the accompanying drawings, I have used reference numeral 10 to indicate a metallic vehicle wheel rim of ordinary construction which, in this instance, is illus-

trated as being a channel-shaped rim adapted to receive a pneumatic tire. It will be understood, however, that I may use, in connection with my invention, any sheet metal ring used as a felloe or rim in connection with such a wheel. The rim 10 is provided at intervals with a plurality of regularly spaced cup shaped sockets 11 which have an opening through their bottom portions designed to slidably receive a spoke. In order to fasten a spoke to the rim the spoke is inserted into the cup member in position where its end will lie within the cup and a pellet such, for instance, as a disk of metal, is placed in the cup adjacent to the end of the spoke. The pellet and end of the spoke are then welded so that they fuse with the cup shaped portion of the rim and with each other, and so that the outer surface of the portion so fused will be substantially flush with the outer surface of the rim. This welding may be accomplished by applying split electrodes to opposite sides of the spoke, these electrodes being provided with recesses adapted to receive the inner surface of the cup 11, so that when the second electrode is applied to the pellet and end of the spoke then the spoke, pellet and cup material will be welded or fused into one piece.

It is also possible to fasten the spokes to the rim by providing an enlargement at the end of the spoke similar in shape to the cup 11, then applying a split electrode, as described, to this cup shaped portion and applying the second electrode to the exterior surface of the rim to fuse the end of the cup shaped portion into the material of the rim.

In the practice of my invention I have welded the spokes to the rim, as heretofore described, prior to their attachment to the hub member. In the form of my invention here shown I have used a cylindrical hub member 12 having a tapered opening 13 therein designed to be fixed to and to receive the end of the axle shaft. The axle shaft may be locked into this hub member in any suitable manner and a hub cap 14 provided to close the end thereof. At the inner end of the hub member 12 an outwardly extending flange 15 is provided which has a plurality of spoke receiving recesses 16, as shown in Figure 4, formed in its periphery by making angular cuts in the periphery through the flange which are substantially equal in width to the width of the

2019 Sponsored Tour and Event Schedule

Feb 14	Membership Meeting
Feb 28-Mar 3	MARC Membership Richmond Hills, GA (Morlock)
Mar 14	Membership Meeting
Apr 11	Membership Meeting
Apr 27	Pancake Breakfast/Cobweb Tour (Sutton, Lawson)
Apr 28	Columbus MARC Swap Meet 4-H Fairground (Morlock, and all members)
May 9	Membership Meeting
May 19-26	National Tour Elkins, West Virginia, Mountain Memories Region
Jun 13-14	Gaslight Auto Tour and Champaign Airplane Museum - Urbana Ohio (Morlock)
Jun 22	Progressive Dinner (Need sponsors, Dean)
Jul 6	Picnic at Brown County Park (Sutton, Lawson, Howell)
Jul 20	Tour of Columbus (Diehn)
Aug 3-11	2019 National Meet Dearborn (Sutton)
Aug 24	Tri-club picnic at Johnson County Park, Indiana Live Steamers (Lawson)
Sep 12	Membership Meeting
Sep 19-23	Gilmore Tour by way of Auburn (Sutton)
Sep 28	CANCELLED - Tour of Indianapolis (Diehn)
Oct 5	CANCELLED - Model A's meet the Hudsons, Ed & Mary Dathe, Bloomington
Oct 10	Membership Meeting
Oct 19	Fall Foliage Tour (Sullivan)
Nov 14	Membership and Election of Officers Meeting
Dec 8	Christmas Party at Pines with Entertainment (Club Officers)

CAR WOOD . . . *America's Speed King*



Car Wood, World's Champion Road Race Driver and head of Car Wood Exhibits, knows more in five words: "When he talks about how-power he has a real message for you."

"Yes... I use Fire-Chief gasoline!"

AND in that one simple statement Car Wood sums up for you a speed racer's contribution based on his own experience as well as laboratory analysis.

We might tell you the technical "why's" and "wherefore's" of Texaco Fire-Chief's superiority. But we believe that you are much more interested in performance—*not* what Fire-Chief is but what it will do for you in the engine of your car.

In Fire-Chief you have a gasoline that will give you more for your money. Some motorists buy Fire-Chief because it's long on miles. Others like it because of its smooth action even on the toughest hill.

Car Wood insists on this "emergency" gasoline because it produces winning speed and power from his engine.

Try a tankful in your car and you will understand why this gasoline is selected by men who know motors. You will agree with Car Wood when he says "Fire-Chief is the finest gasoline I ever used."

THE TEXACO COMPANY • Texaco Petroleum Products

TEXACO FIRE-CHIEF
"EMERGENCY" ACTION IN EVERY DROP



2019 On Your Own Tours

May 17-18	Hoosier Vintage Wheel Swap Meet, Franklin
May 25-27	Memorial Day Weekend
Jun 1	Elizabethtown Parade - lineup 10am, parade 11am. Contact Gale Greathouse 812-390-9857
Jun 1-3	Annual Model A Day Sharon, WI (Howell)
Jun 16	Happy Father's Day
Aug 1-4	Pioneer Engineers, Steam Engines 3707 S 200 W, Rushville, IN
Aug 17-18	Greensburg Power of the Past
Aug 20-24	Tri-state Gas Engine and Tractor Show at Portland
Sep 8-9	Scottish Festival, Columbus
Sep 26-29	Franklin County Antique Machinery Show
Sep 14	Hot Rods and Rock & Roll, Columbus IN
Sep 16-17	Hoosier Vintage Wheels Swap Meet and Show Johnson County Fairgrounds
Oct 6	Indiana region of the Classic Car Club of America, High Point Orchard, Greensburg, IN
Oct 7	Newport Antique Hill Climb (Sep 29-Oct1)
Oct 9-12	Hershey Swap Meet, Hershey PA

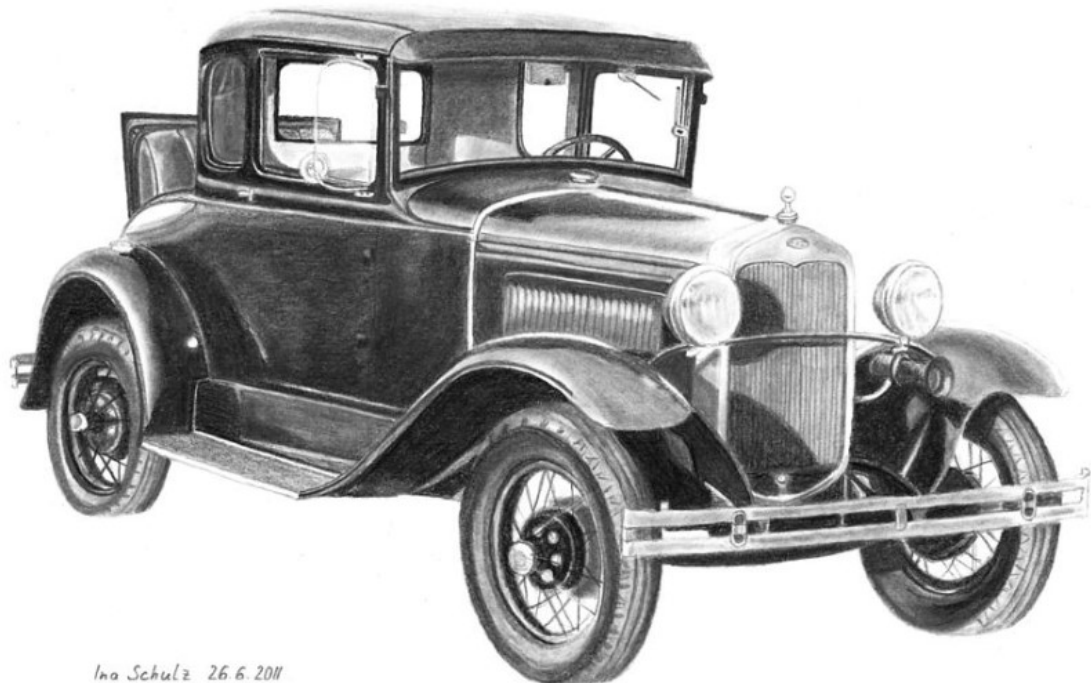

2019 Club Officers & Leadership

President

Ron Lawson
812-343-2434
ronlaw69@yahoo.com

Vice President

Roger Dean
812-278-6696
Deanhome.dean@gmail.com

Secretary/Club Reporter

Nora Dean
812-592-7417
Deanhome.dean@gmail.com

Treasurer/Tour Master

Phil Sutton
812-336-8672
pgsutton@indiana.edu

Board of Directors

Wayne Arnholt
812-522-1007
aatruckway@aol.com

Tim Diehn
812-374-2882
timdiehn@yahoo.com

Jack Sullivan Jr.
812-523-3674
roadsterman1929@yahoo.com

Web Master/Membership

Larry Riss
812-342-7644
risslarry@comcast.net

Newsletter

Tim Diehn
812-374-2882
modelacolumbus@gmail.com

Swap Meet Chairman

Larry Morlock
812-371-6628
l.morlock@att.net

Care and Concern Committee

Linda Sullivan
812-523-3674
roadsterman1929@yahoo.com

Going Places is the official publication of the Columbus Model A Restorers Club Region and the Columbus Model A Ford Club of America Chapter. The general purpose shall be to encourage the members to acquire, preserve, restore, exhibit and make use of the Model "A" Ford vehicle, model years 1928 through 1931 and all things pertaining to the Model "A" Ford, including literature, technical and historical information and to promote the introduction of ideas and fellowship for the enjoyment of its members.

This publication is mailed or emailed to members and editors of similar publications monthly. Meetings are the second Thursday of the month. We invite members to submit articles containing technical Model A information and other interesting tidbits for publication in this newsletter.

Classifieds



For Sale

1928 Model A Roadster

5 new 16" tires/wheels, engine rebuilt ~50 hours of run time, new seat cover, steering wheel is a duplicate of the original red wheel (have original), trunk can be converted to rumble seat, new windshield and rear view mirror.

Call 270-535-6670 Jim Bowers.

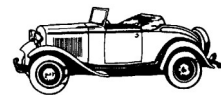

For Sale

1931 Model A Roadster Deluxe

Easy steer, F-150 transmission, turn signals, 12 volt battery, trunk rack, seat belts, and CB antenna, etc. Great driver and has no issues. In a trailer garage near Pensacola, Florida. Can meet down there and stay at our condo on the beach.

Asking \$18,900

Call/Text 812-322-8280 Ruth Engs

